

# RS-009

**FEATURES:**

- \* Sink Size: 20 1/2" x 15 1/2" x 6 3/8"
- \* Material: Blanca Carera
- \* Counter Top Sink
- \* Recommended Drain: DS-003
- \* For Use With Standard Pop Up Drain
- \* Warranty: One Year Limited Warranty

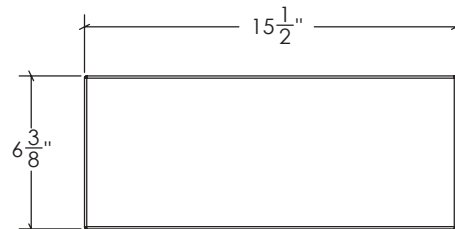
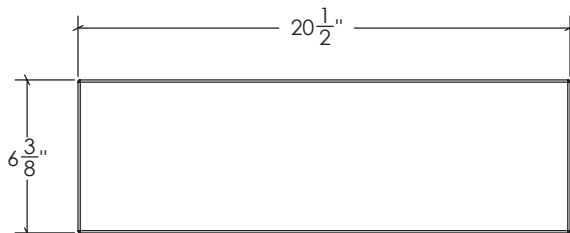
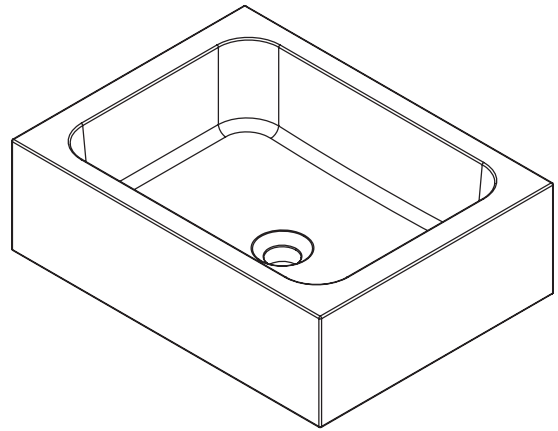
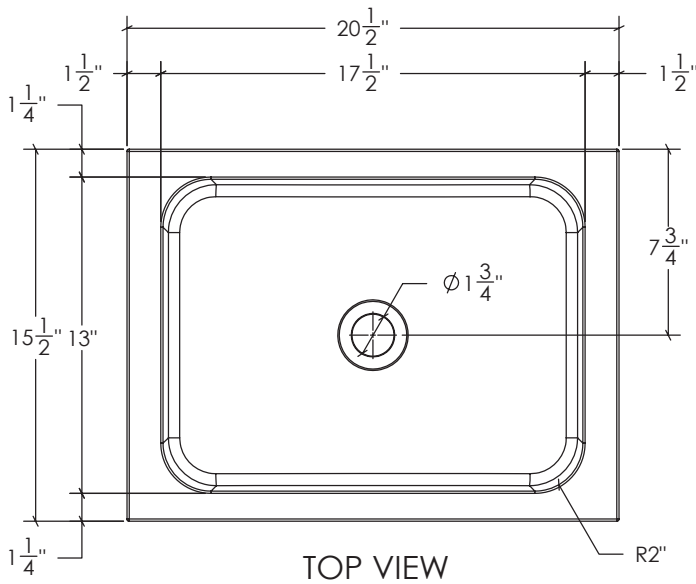

## JOB INFORMATION:

Job Name \_\_\_\_\_  
 Date Specified \_\_\_\_\_  
 Contractor \_\_\_\_\_

\* Specifications and drawings provided on this sheet are for illustration only. Cantrio Koncepts will not be held responsible for cutouts made without the actual product or product template.